



# The Story Begins



The Project “**Changing Oceanographic Conditions of the Sea Of Marmara**” was first begun in 1954 by marine biologists Olav Aasen and İlham Artüz in the Meat and Fish Office.

# E.B.K.

Et ve Balık Kurumu  
(Meat and Fish Office)

- When the Hydrobiological Research Institute of I.U. Faculty of Science was established in 1957, that project became periodic and was carried regularly until 1982.

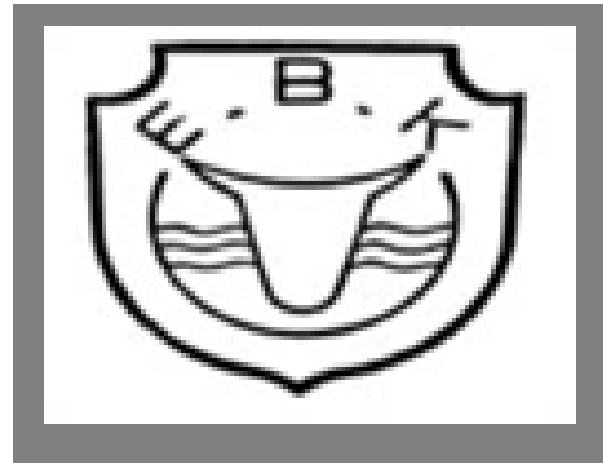
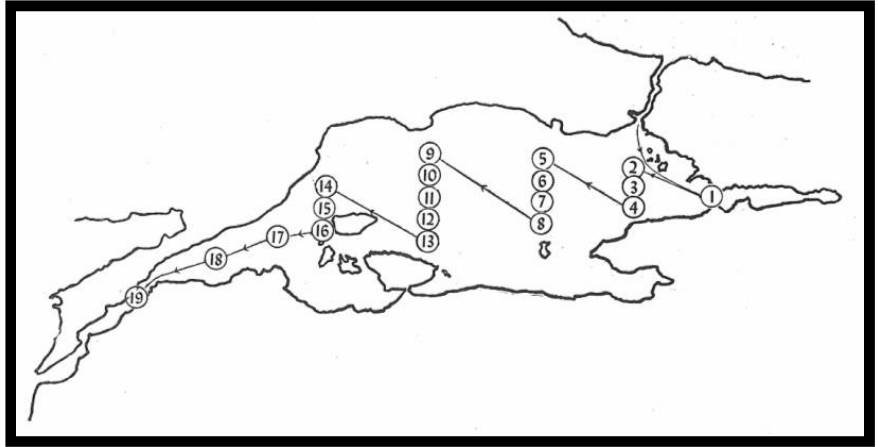

# Research Ship Name ARAR

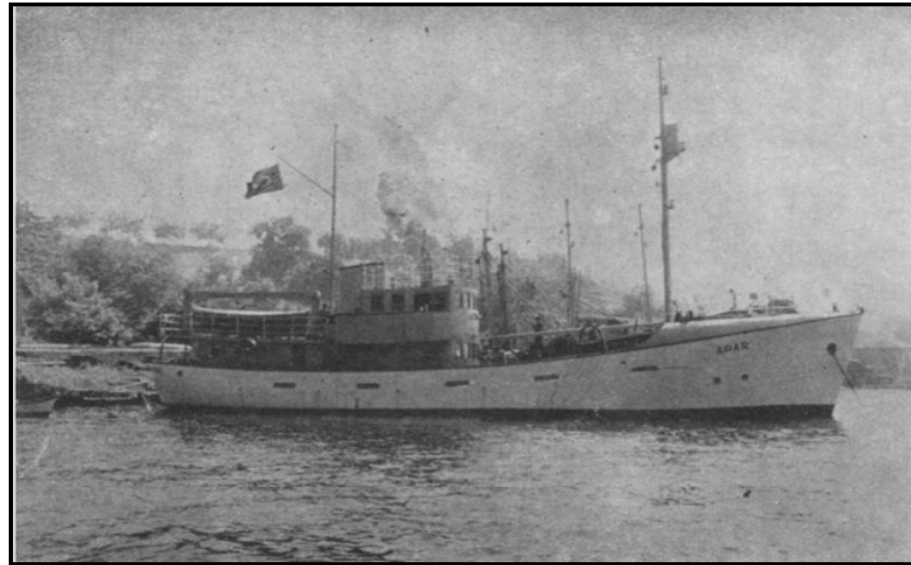

- With the close of Hydrobiological Research Institute in 1980s that project's responsibility was taken on by I.U. Faculty of Environmental Sciences headed by İlham Artüz and was carried on regularly until the end of 1980s.

# İ.T.Ü.

## Istanbul Technical University



- From the end of 1980s on that project, again with leadership of İlham Artüz was continued at the İ.T.Ü. Faculty of Naval Architecture and Ocean Engineering. After İlham Artüz passed away in 1993, marine biologist M. Levent Artüz headed the project in the first year at I.T.Ü. Faculty of Naval Architecture and Ocean Engineering along with the measurements of I.U. with the aim of continuing periodic computation.

# Project Continues

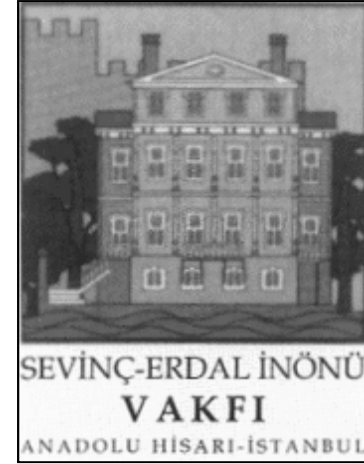

- In the following years, that project was continued with the efforts of M. Levent Artüz and it has been held up by the Foundation of Sevınc-Erdal İnönü since 2006.

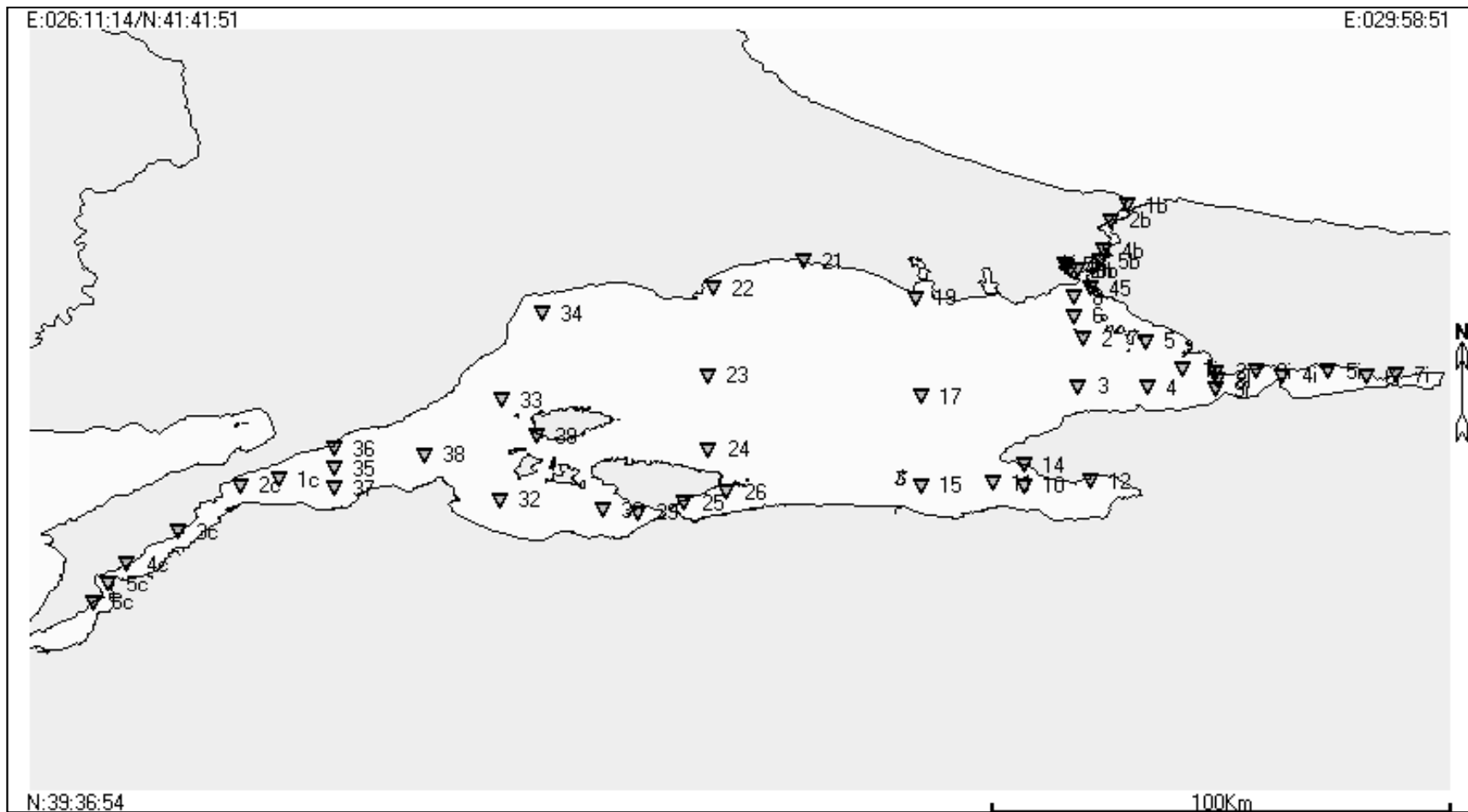

- The main project “**Changing Oceanographic Conditions of the Sea Of Marmara**” is the longest monitoring project that ever been done for any of the seas. From 1954 to these days, at the Sea of Marmara and the Turkish straits, horizontally at 50 stations, there were about 25 parameters have been observed at the convenient depth cutaways (0.5m.-1200m.).

# Marem Program

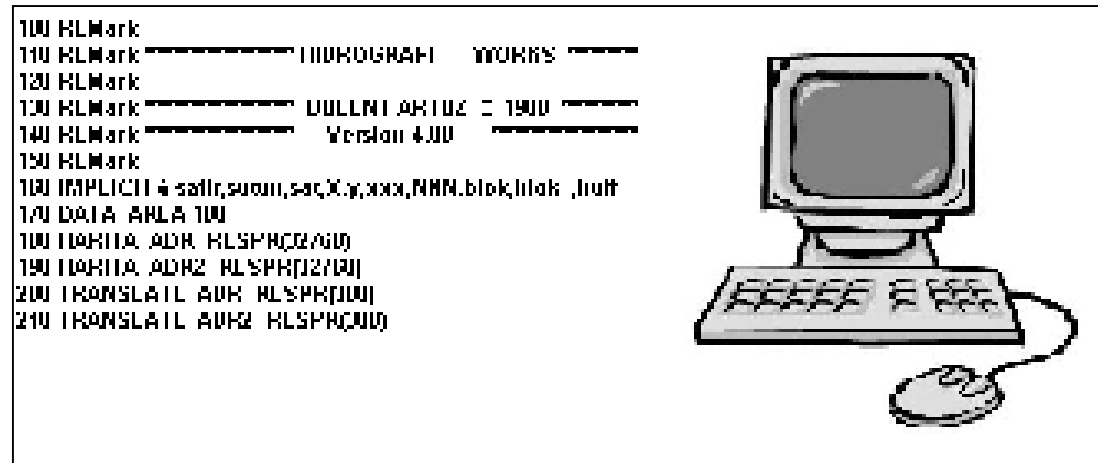

- Firstly in 1980, taking the Sea of Marmara into consideration, all the studies about the sea were wished to be put together to have a data base by İlham Artüz. Subsequent to that idea especially beginning from 1954 and taking the observation results into account of the Meat and Fish Office and Hydrobiological Research Institute, the data and calculations were digitalized in 1980s.



# Marem DataBase

DATA TABLOSU											
Tarih:	1/08/2009		Seri_No:	aaydemir-19		Arz:	N41°:09':30"		Tut:	E029°:04':13"	
Saat:	11:13		İstasyon No:	2b		Proje:	Iartuz-MAREM-2009-Yaz-H		Derinlik:	12 m	
Sec-Disc Der.:	9	m	Renk Kodu:			Hava Sic.:	28	T°C	Hava Bas.:	1035	mbar
Der	T°C	Sal	Cl	SIGMA-T	mmhos	S.Sp	DO mg/l	DO m/l	pH	Hz	Yön
0.5	23.32	18.78	10.39	11.66	30.27	1.512.65	8.11	5.68	7.6		
2.347	23.87	18.5	10.23	11.29	29.85	1.513.83	6.3	4.41	7.56		
3.696	24.06	18.43	10.19	11.18	29.75	1.514.27	6.83	4.79	7.49		
5.105	24.11	18.44	10.2	11.18	29.77	1.514.43	6.9	4.84	7.43		
6.336	24.12	18.44	10.2	11.18	29.77	1.514.48	6.94	4.86	7.38		
7.506	24.07	18.44	10.2	11.19	29.77	1.514.37	6.93	4.86	7.36		
8.118	24.05	18.45	10.2	11.2	29.77	1.514.34	7.02	4.92	7.35		
9.156	24.03	18.44	10.2	11.21	29.77	1.514.29	7.02	4.92	7.33		
9.641	24.01	18.45	10.2	11.21	29.77	1.514.26	7.06	4.95	7.32		
9.659	24.00	18.45	10.2	11.21	29.77	1.514.23	7.1	4.98	7.29		



- Up to now from 1990 a seriously huge in-situ equipment park has been created to carry out this project for making these observations.
- Multi-discipline structure of the project shows itself in every subject. O. Bülent Artüz who educated on Electronic Engineering and developed his applications on system programming and project management softwares for years also developed an environment which can be tested and used for this project.

# Development

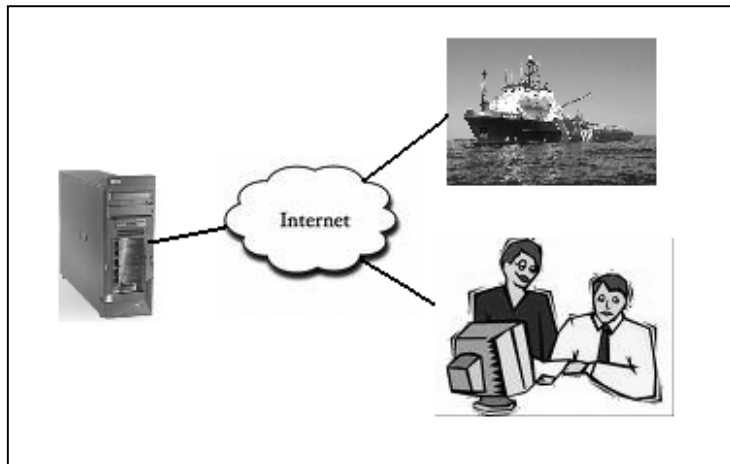



- For reach out and share and help to more scientist, we developed a project management environment for this kind of researches, and also gave an opportunity to use this management and reporting system over internet, for the ones who can freely sign up and use.
- Explorers, can easily enter and seize their data to system and share with other researchers with maximum security, and also distribute their work over internet on this systems web page, if they want.

# Outputs

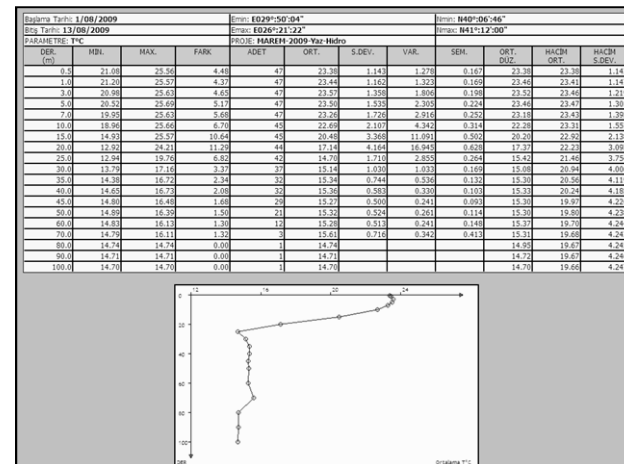
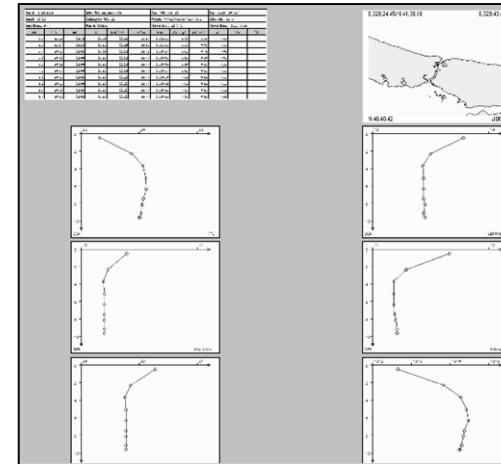
- System gives the explorers opportunity of storing their data and also calculating and displaying outputs graphically, positioning the location on a dedicated map.

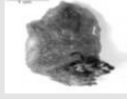

	38	<u>11-fustun</u>	htorcukoc	MAREM-2009-Yaz-Bentik	algarna-10
					
<i>Aspinigla cuculus</i>					
S	Bulunduđu Kart	Sahibi	Proje	İstasyon	
39	<u>1-fustun</u>	htorcukoc	MAREM-2009-Yaz-Bentik	algarna-1	
					
<i>Asterias amurensis</i>					
S	Bulunduđu Kart	Sahibi	Proje	İstasyon	
40	<u>11-fustun</u>	htorcukoc	MAREM-2009-Yaz-Bentik	algarna-10	
<i>Astropecten bispinosus</i>					
S	Bulunduđu Kart	Sahibi	Proje	İstasyon	
41	<u>8-fustun</u>	htorcukoc	MAREM-2009-Yaz-Bentik	algarna-7	
					

- After the latest updates, the system is not only prepared for storing physical data but also for the classification of living matters and measurement results, to store their photos and mass measurements in a new database.

Researchers can use this database to display their data over internet, using this system, graphically and positioning on maps

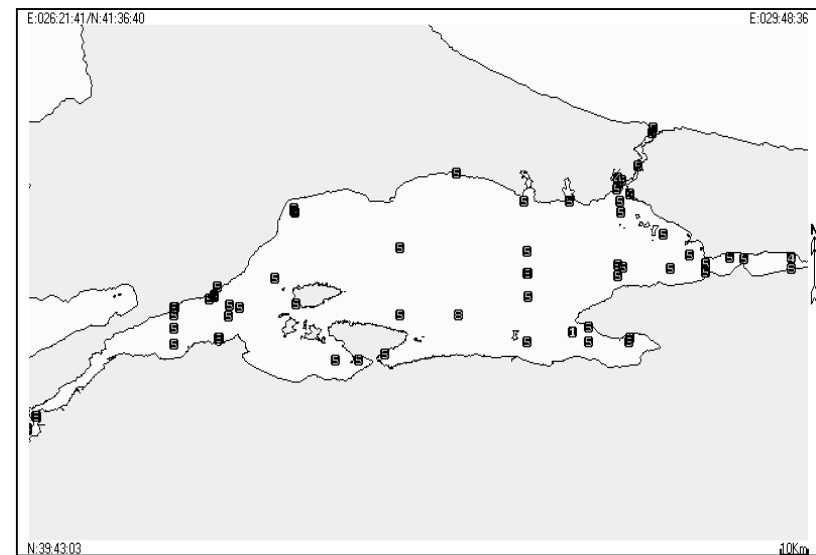

# Search&Find

- After input, detailed data to a project, it is so easy to find and display the distribution of individual life form to whole data that input for the projects.
- System gives many opportunities to a project leader. Project leader can assign jobs to project staff and let them work for the project. After the project is over, the project leader can easily trace the works with detailed reports.

MATERİYAL DAĞILIMI	
SAHİBİ:	---
ÇALIŞANI:	---
PROJE:	---
ÇEKİŞ YÖNÜ:	---
MATERİYAL FR:	<div style="border: 1px solid black; padding: 2px;"><div style="display: flex; justify-content: space-between;"><span>Kat Döşeme</span><span>↕</span></div><div style="font-size: 0.8em; padding: 2px;">AA AB Açık alba AC Acanthocephala pupurea Acanthocephala acirata Acanthocephala Acanthocephala</div><div style="display: flex; justify-content: flex-end; align-items: center;"><span>←</span><span>↔</span><span>→</span></div></div>
BASLANGIÇ TARİHİ:	11/07/1993
BİTİŞ TARİHİ:	13/08/2005
AYKIRI:	<input type="checkbox"/>
YAZILI OLANLAR:	<input type="checkbox"/>
BOVUT:	800x450 (Dikdörtgen)
İKON SETİ:	S=11

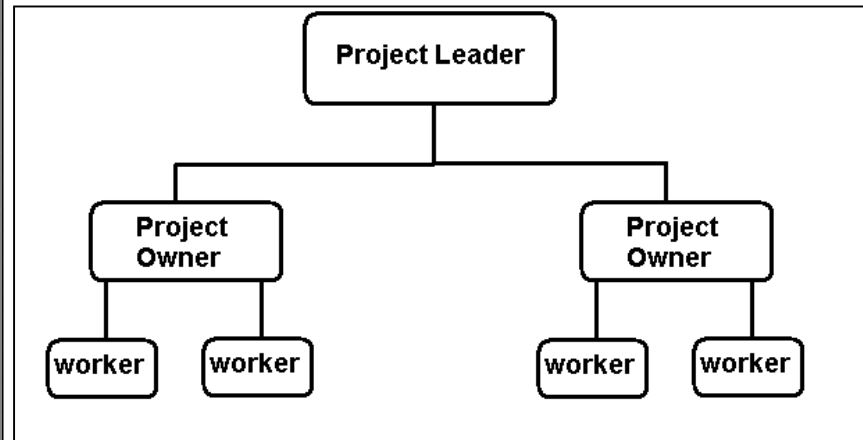

# Distributed Research

- This system can be used on field. After getting data from physical environment and entering the system on field, the shared people can view outputs over internet. It is also possible for the project leader to administrate the project form a different location.
- With this opportunity, sub-project groups can be on different locations, but under the same covered project and administrated by a single leader, with the help of internet connection.

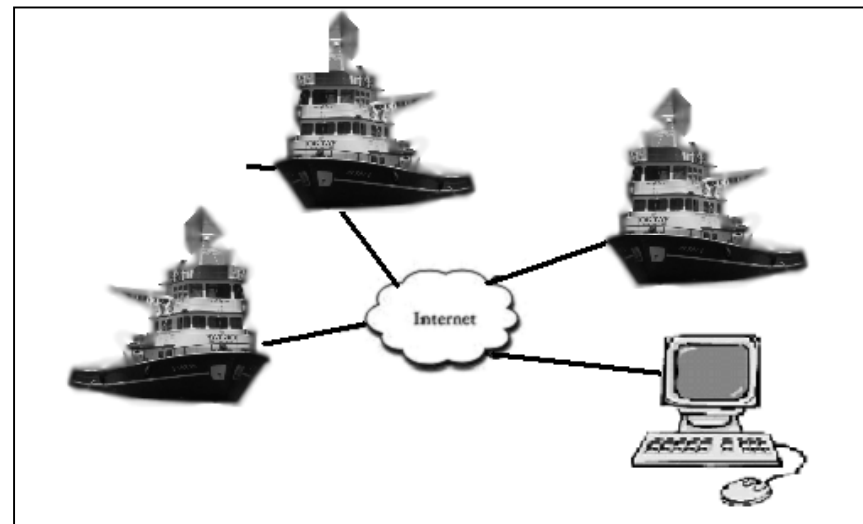



# On Field Operation

- Today's projects can be entered as they are worked on field directly from the measurement units, the previous projects before this system which are published on paper, were also entered to this database by our project group. So they can use, to watch and calculate the evolution of the environment in years, for the main purpose of this process.





# Sea of Marmara

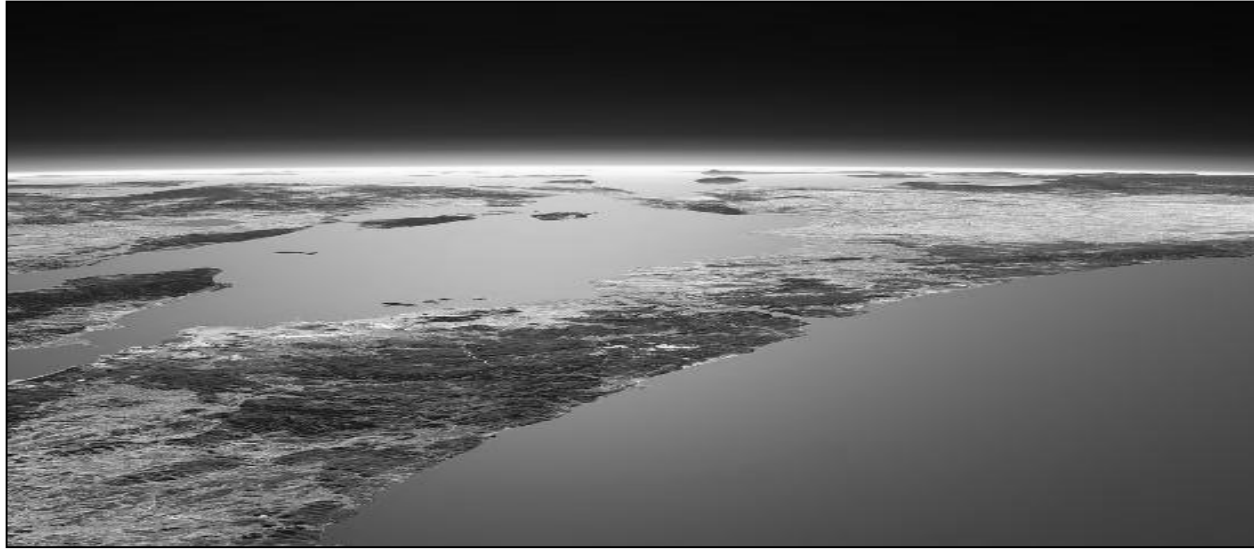

- Since 1681 up to now there have been a lot of researches both at the Sea of Marmara and the Bosphorus which were composed of wide variety of subjects. Data that were kept as a result of the research made a base for learning the basic structure of water mass which has an interesting and huge dynamism.

# Break Point

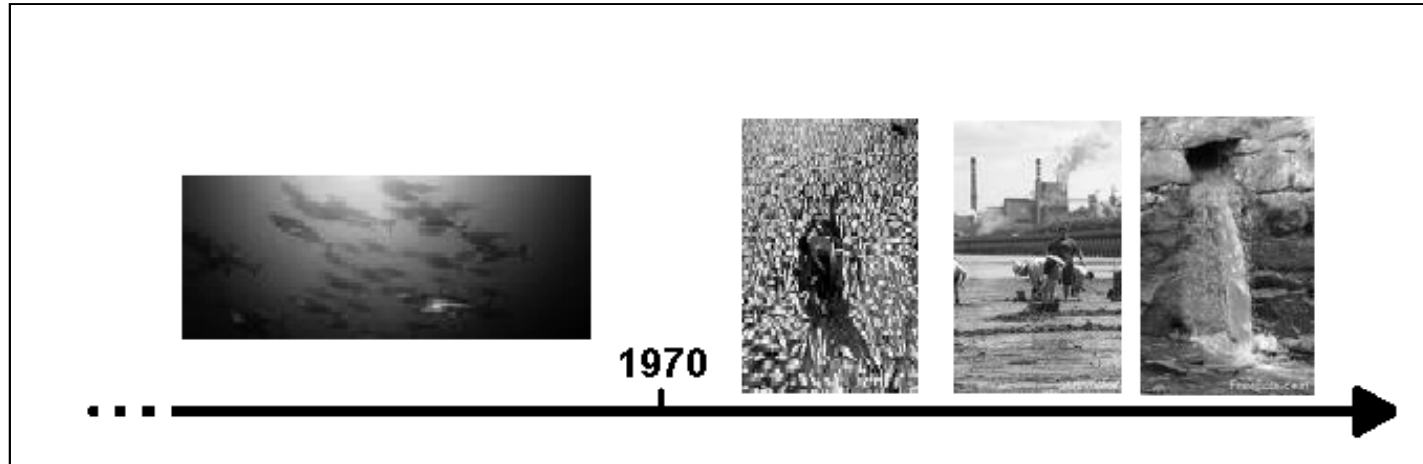

- The Sea of Marmara didn't show any difference until 1970s but, after that there have been plenty of changes because of the growing industries, remaining of sea transport, and densely booming of population. Unfortunately these changes still continue.
- Until 1970's the Sea of Marmara contributed producing seafood in 22%, but after the beginning of 2000s it dropped back at the rank of 5%.

# Revenge of Nature



- Due to densely rise of decomposed and/or suspended materials, the depth of the solar energy, which makes primer productivity of sea, decreased. As a result of the fact not only the productivity of oxygen by photosynthesis but also the oxygen that came to the ecosystem of the Sea of Marmara with drop down and/or interaction of atmosphere, which is composed of a material especially organic or oxidized, decreased.
- The factor that prevents light penetration at the Sea of Marmara makes accumulation at the base in times.

- Besides this, the outflow from the Black Sea basin is a function of its water budget and carry runoff from the large rivers and surface waters running into the Black Sea.
- The salinity of the inflowing Mediterranean water which is over 38.50 ‰ Sal. at the entrance of the Dardanelles decreases slowly with the distance traveled in the Sea of Marmara down to 29 ‰ Sal. where the current enters the Black Sea, at the northern end of the Bosphorus. The water masses of the Black Sea are entirely different from those of the Mediterranean proper. Because that, the influence is limited between the layers, over and under the thermo-halocline.
- In other words, Sea of Marmara occurs from two different water masses, from two different upset seas.

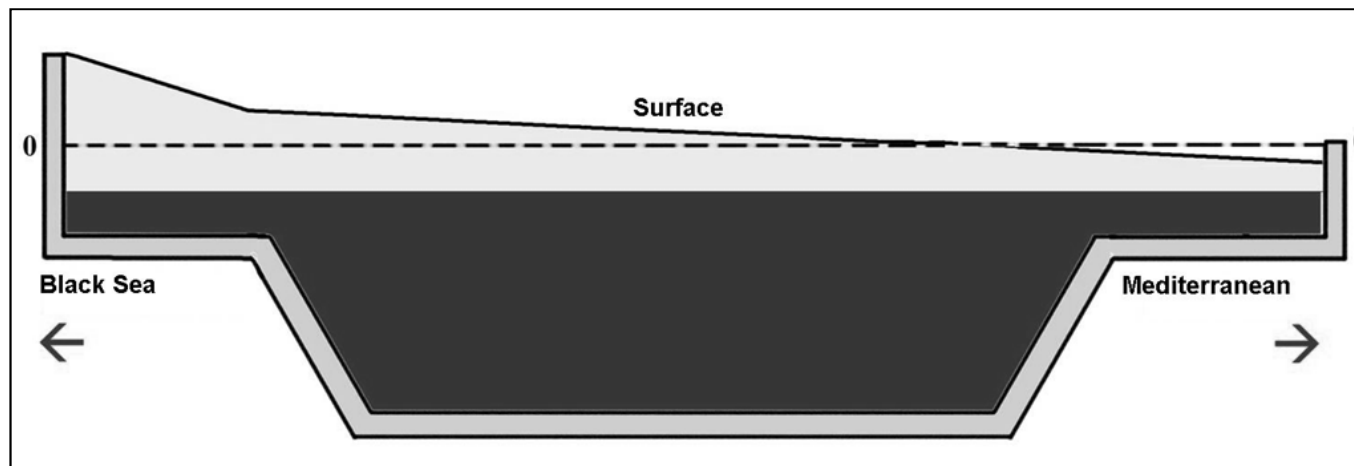

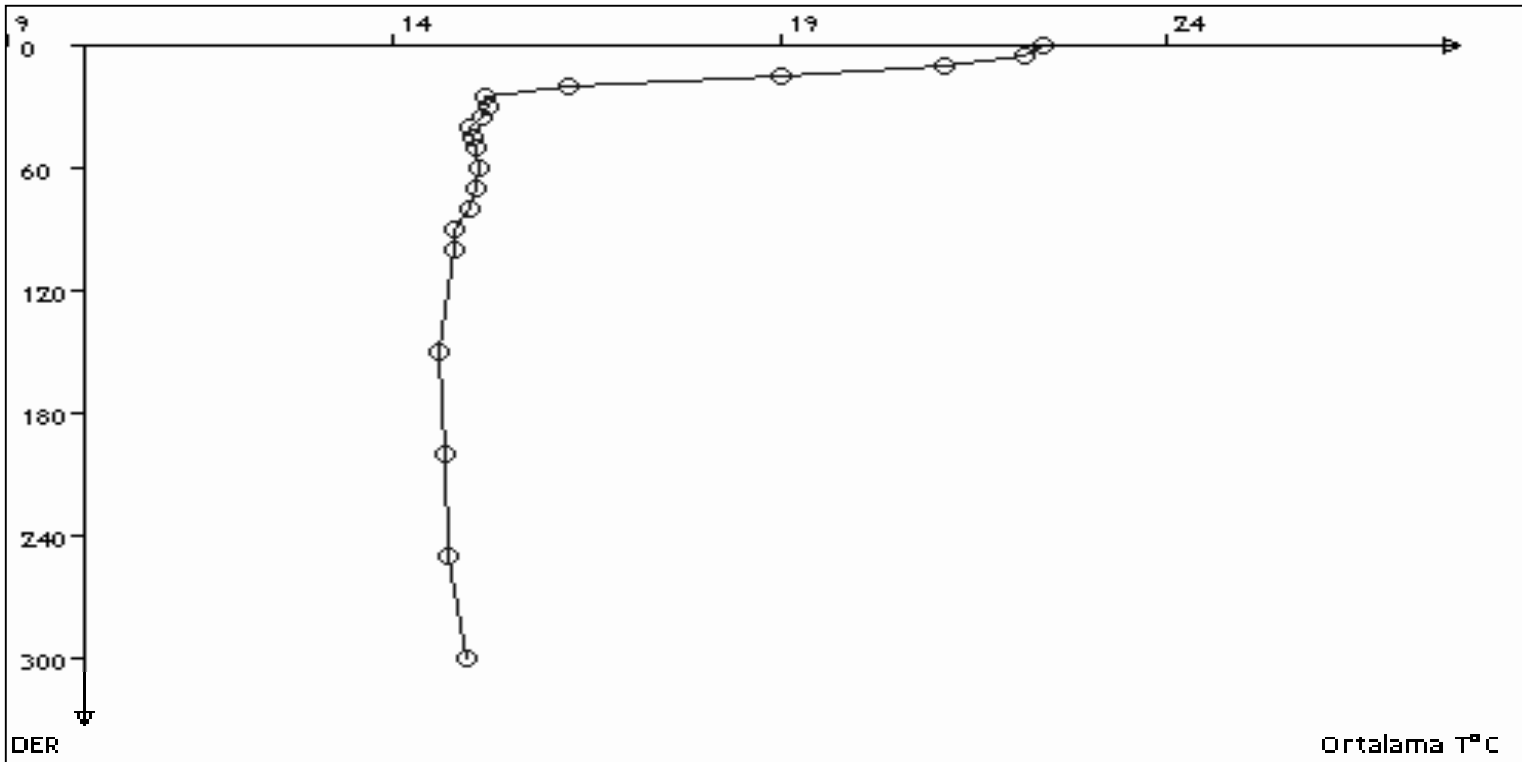

- While the water temperatures of Black Sea sourced upper water mass variable between 50-75m. in thickness depending on the amount of incoming water from the Black Sea and, especially, seasonal changes, change between 6 °C and 27 °C, the temperature changes in the deeper water mass shows virtually no change, fluctuating by 0.8 °C between 15 °C~14.2 °C throughout the year.
- For example; because under the mass of cold water as 14 °C there occurs a mass of warm water, this is described as inversion.

# Thresholds

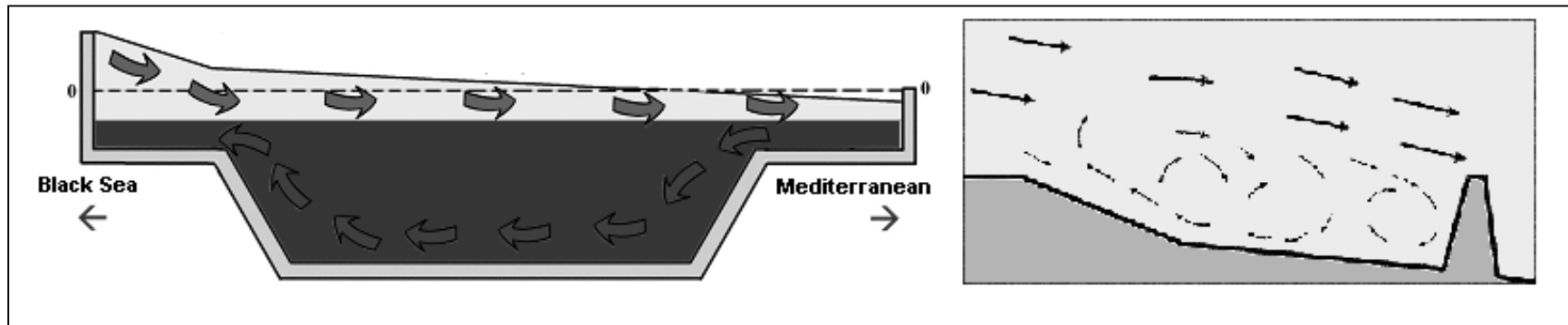

- The Sea of Marmara has a limited place for exchanging of materials with Black Sea, Mediterranean and Aegean Sea because of the Bosphorus that has narrow and shallow thresholds.
- As a result of that it has a rich biological form which has different biological events and different forms at different layers.

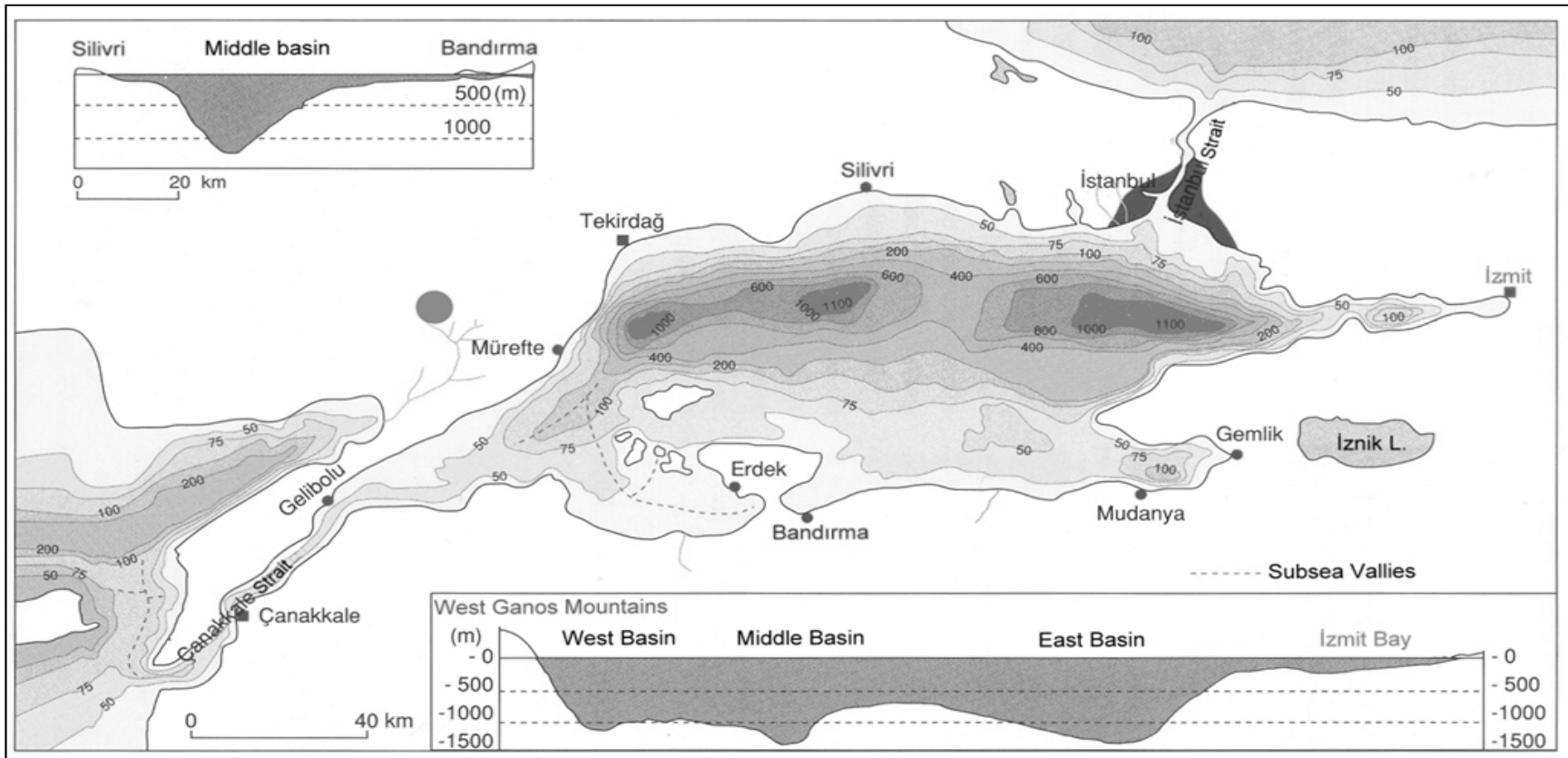

- One of the factors that create this difference is the places that are connected to earthquake faulting structure at the Sea of Marmara. These places differ from the others, because there are different mineral concentrations, different gas concentrations due to the activity of earthquake fault, micro cosmos places occurred due to the warm water that exits to the layer along with the earthquake fault and habitat that is occurred as a result of the geological deformation because of the earthquake fault.

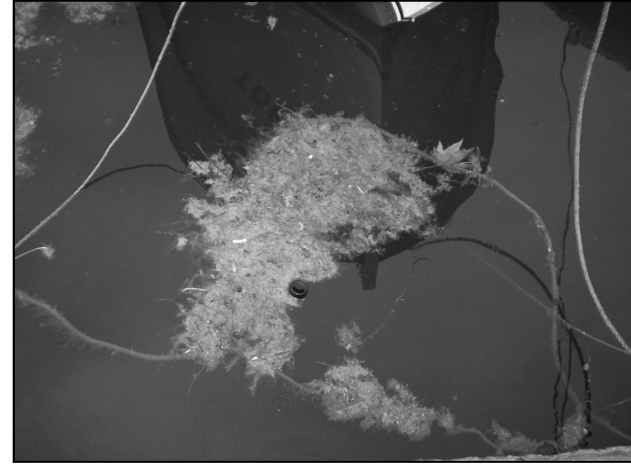
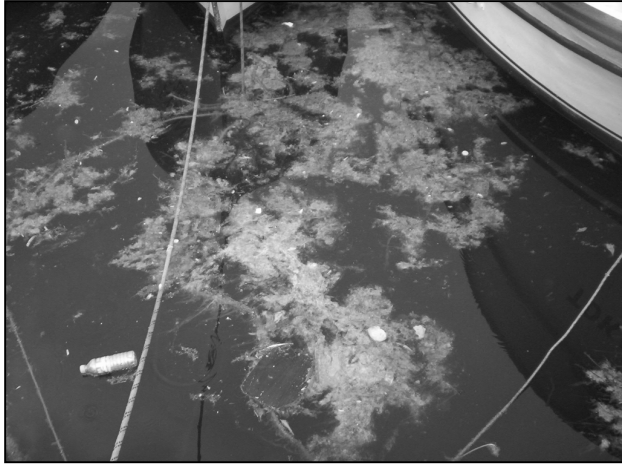

- The previous studies and data that show the biological and oceanographical features of Sea of Marmara ease to make us aware of its dimensions today concerning the speed of changes and the dynamism with their effect on each other. Yet the appreciation of the real situation is still impossible. Depending on the previous researches the project will certainly provide the future projects of Sea of Marmara on engineering, economy, transport and etc. with great help besides serious precautions and scientific support in the protection of Sea of Marmara and its environment.



# With these briefly expressed reasons the project handles

- **1.** Indication of the latest oceanographical stage of the upper and lower layers of Sea of Marmara,
- **2.** Sustainability of the database at the view of ecology, fauna and flora, and changing oceanographical conditions,
- **3.** Indicating the long term development speed and trend of Sea of Marmara, by using the recent and revolving measurements and survey results,
- **4.** Creating scientific databases and proposal packages for different projects and representations for planned aims for any future projects of Sea of Marmara and Turkish straits,
- **5.** Providing the students of different levels from other related disciplines with in-situ educational facilities, in accordance with the survey program of our foundation
- **6.** Building a unity among different resource groups in the field, with different research facilities and without any coordination of resource results, laboratory facilities and instrument parks, located around Sea of Marmara.
- **7.** Creating original scientific publications that are based on observations, analyses and views of scientists.

# To Contact Us

**Levent Artüz:** [levent@artuz.com](mailto:levent@artuz.com)

0532 415 72 85

**Bülent Artüz:** [bulent@artuz.com](mailto:bulent@artuz.com)

0532 416 65 81